

Instrumentation Products

Ball Valves and Ball Valve Manifolds

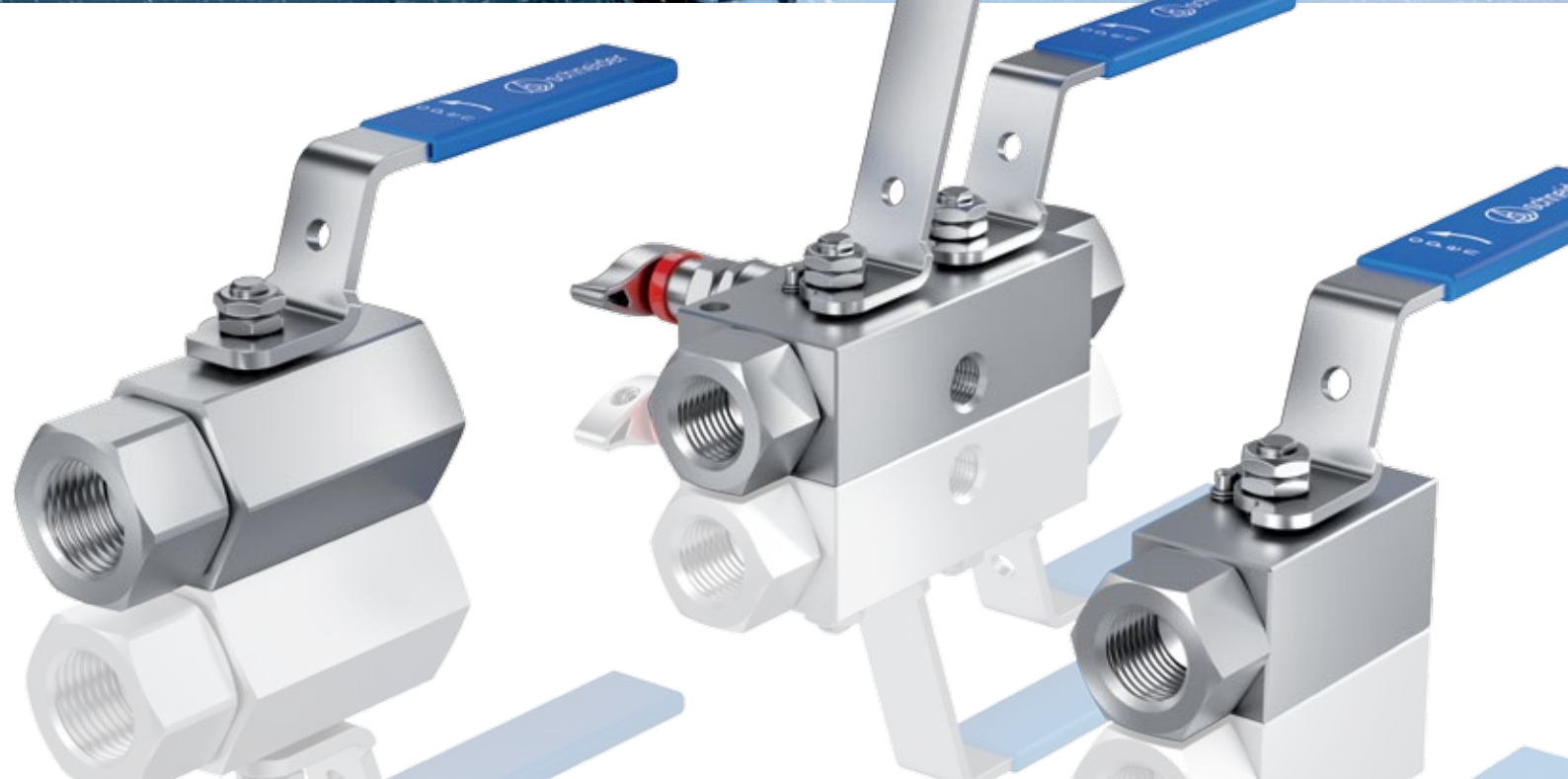

Introduction

Introduction

The AS-Schneider Group with its headquarters in Germany is one of the World's Leading Manufacturers of Instrumentation Valves and Manifolds. AS-Schneider offers a large variety of Ball Valves, Ball Valve Manifolds and the relevant Accessories required for instrumentation installations globally.

Selection can be made from a comprehensive range of bodies with a variety of connections and material options, optimizing installation and access opportunities. Many of the valves shown in this catalogue are available from stock or within a short period of time. The dimensions shown in this catalogue apply to standard types. If you need the dimensions for your individual type please contact the factory.

Continuous product development may from time to time necessitate changes in the details contained in this catalogue. AS-Schneider reserves the right to make such changes at their discretion and without prior notice.

All dimensions shown in this catalogue are approximate and subject to change.

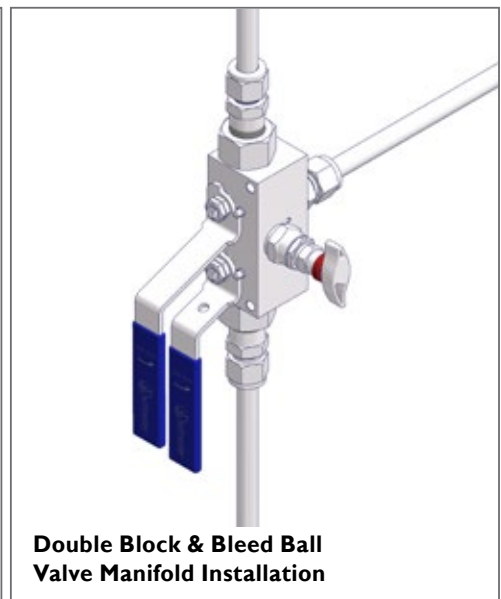
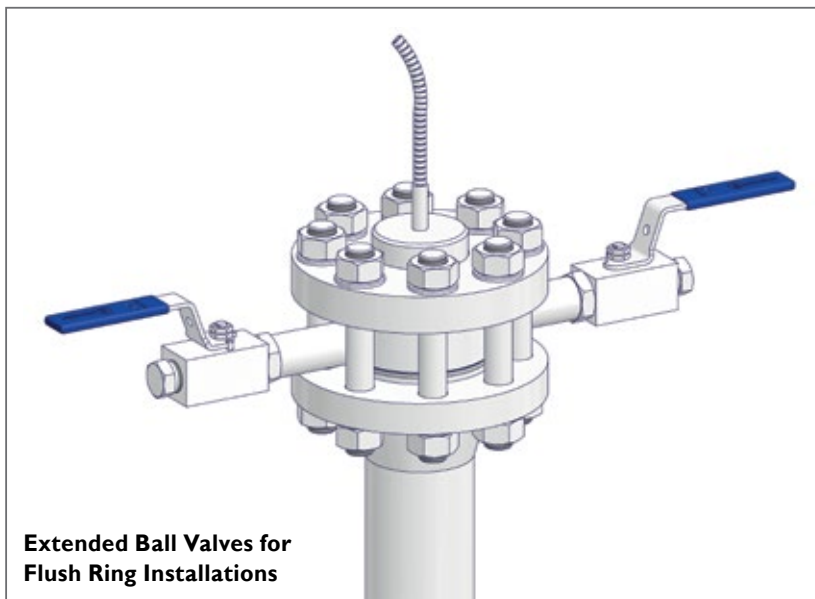

Introduction	page 2
Contents	page 3
KA, KB & KC Series Ball Valves I General Features	page 4
KA, KB & KC Series Ball Valves I Materials	page 5
KA Series Ball Valves	
Standard Ball Valve Design	page 6
Dimensions	page 7
KB & KC Series Ball Valves	
Standard Ball Valve Design	page 8
Dimensions	page 9
KA, KB & KC Series I Options	page 10
KA, KB & KC Series I Ordering Information	page 11
BA Series Double Block & Bleed Ball Valve Manifolds	page 12
BA Series Block & Bleed Ball Valve Manifolds	page 13
BA Series Ball Valve Design	page 14
BA Series Needle Valve Design	page 15
BA Series Dimensions	page 16/17
BA Series Materials and General Features	page 18
BA Series Ordering Information	page 19
K Series Ball Valves	
Standard Ball Valve Design	page 20
Dimensions	page 21
KM Series I Metal Seated Ball Valves	page 22
Low Pressure Ball Valves 1,000 psi (69 bar)	page 23

KA, KB & KC Series I General Features

Standard Features

KA Series

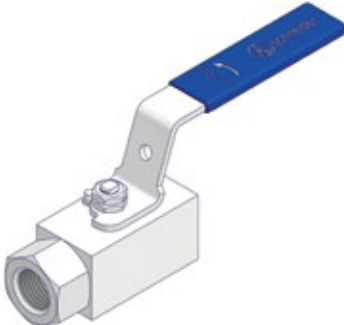

KB Series



KC Series



Series	KA	KB	KC
Bore Size mm (inch)	Ø 10 (0.39")	Ø 14 (0.55")	Ø 20 (0.79")
Basic Design	2 Piece Body Design		
	Anti-Blowout Stem		
	Floating Ball Design – Bi-Directional		
	Low Operating Torque		
	Anti-Static Design acc. to ISO 17292		
Body Shape	Square	Hexagon	
Seat Material / max. allowable (Working) Pressure (PS) bar (psi)	Reinforced PTFE 420 (6,092)	PEEK 420 (6,092)	
	PEEK 420 (6,092)	Reinforced PTFE 150 (2,175)	
	PEEK 689 (10,000) Uni-Directional		
Stem Seal Material	PTFE or Graphite	Reinforced PTFE	
Fugitive Emission Application		Tested and certified acc. to ISO 15848-1	
Fire Test		Fire-type tested and certified acc. to ISO 10497 / API 607 – For PEEK Ball Valve Seat only	

Sour Gas Service:

Wetted parts according to a.m. material list are supplied as standard according to NACE MR0175/MR0103 and ISO 15156 (latest issue).

Low Temperature Service:

On request.

Oxygen Service:

On request.

Pressure Test:

A shell test at 1.5 times the max. allowable (working) pressure and a seat leakage test are performed acc. to EN 12266-1 - P10, P11 and P12 respectively MSS-SP61 (and complies also with ASME B31.1 and B31.3) at every standard AS-Schneider Ball Valve → 100% Pressure Tested!

Pressure Test acc. to API 598 on request.

Certification:

Certified Mill Test Report (CMTR) as Inspection certificate 3.1 acc. to EN 10 204 for valve body material and pressure test available on request.

PMI Test on request.

Handle Options and Body Design Options see Page 10.

Manufactured acc. to the following Codes and Specifications

- ASME B16.34 Valves – Flanged, Threaded and Welding End
- ASME B31.3 Process Piping
- ASME B31.1 Power Piping

Body Material Options

Material Group	AS Material Designation	Material No.	Short Name	Equivalent UNS-No.	Material Grade acc. to ASTM	Ball Valves
Carbon Steel	A105				A105	Optional
Austenitic Stainless Steel	316 quadruple certified*	1.4401	X5CrNiMo17-12-2	S31600	316	Standard
		1.4404	X2CrNiMo17-12-2	S31603	316L	Standard
	6Mo	1.4547	X 1CrNiMoCuN20-18-7	S31254		Optional
Austenitic-Ferritic Stainless Steel	Duplex	1.4462	X2CrNiMoN22-5-3	S31803	F51	Standard
	Superduplex	1.4410	X2CrNiMoN25.7.4	S32750	F53	Optional
Nickel Based Alloys	Alloy 400	2.4360	NiCu30Fe	N04400		Standard
	Alloy C-276	2.4819	NiMo 16 Cr 15 W	N10276		Standard
	Alloy 625	2.4856	NiCr22Mo9Nb	N06625		Optional

* Quadruple certified means 316 / 316L / 1.4401 / 1.4404

Ball Valve Components

Components	Carbon Steel	Stainless Steel	Exotic Alloys					
	Material / Material No.							
Body	A105	316 / 316L	Alloy 400	Alloy C-276	Duplex	UNS S32750	Alloy 625	6Mo
Body End Connector								
Ball	316 / 316L							
Stem								
Ball Seat	Reinforced PTFE or PEEK							
Body Seals (KA Series only)	PTFE, Reinforced PTFE or Graphite							
Stem Seals								
Gland	316							
Hex Nut	316							
Handle	316							
Handle Grip	Vinyl							
Stop Pin	A4							
Anti-Static Spring	316							

Wetted components listed in **bold**.

KA Series I Standard Ball Valve Design

Standard Ball Valve Design – Bore Size 10 mm (0.39")

Screwed Design – Stem Seal: Packing

Features

- Floating Ball Design
- Ball Valve Seat:
 - Reinforced PTFE or
 - PEEK
- Ball Seats are encapsulated in end connector / body
- Stem Seal: Standard Packing in PTFE and Graphite
- Anti-Static Design as Standard acc. to ISO 17292
- Anti-Blowout Stem Design
- Seat Leakage Class VI acc. to ANSI/FCI 70-2
- Max. allowable (Working) Pressure (PS): 420 bar (6,092 psi) with PTFE and PEEK Seats → Bi-Directional
- Max. allowable (Working) Pressure (PS): 689 bar (10,000 psi) with PEEK Seats only → Uni-Directional
- Positive Stop Pins
- All Non-wetted Parts in 316 Stainless Steel

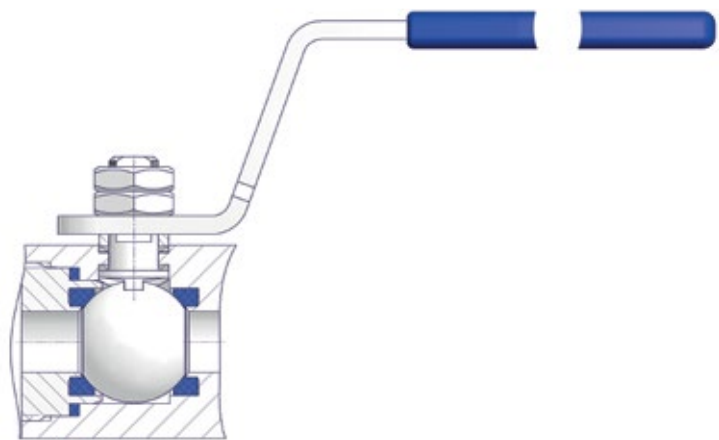
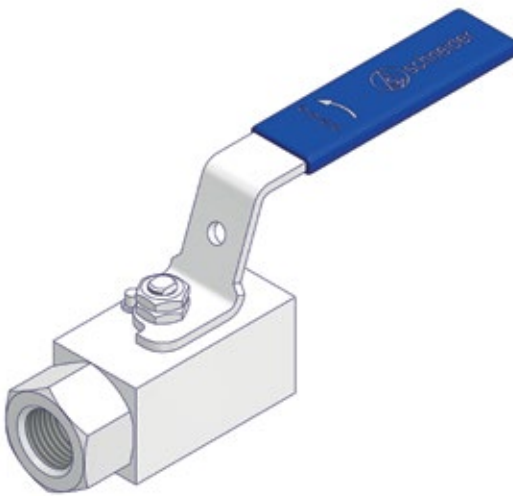

Pressure-Temperature Ratings

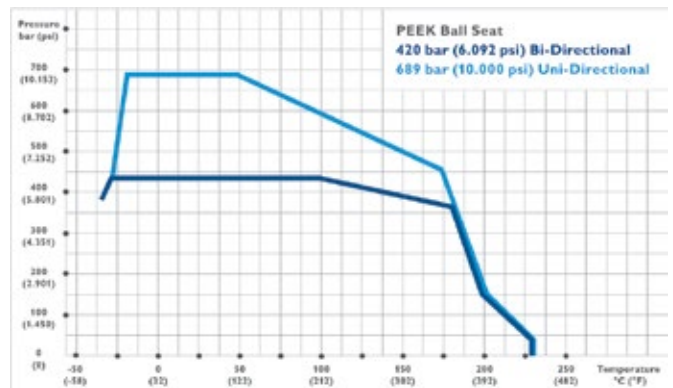
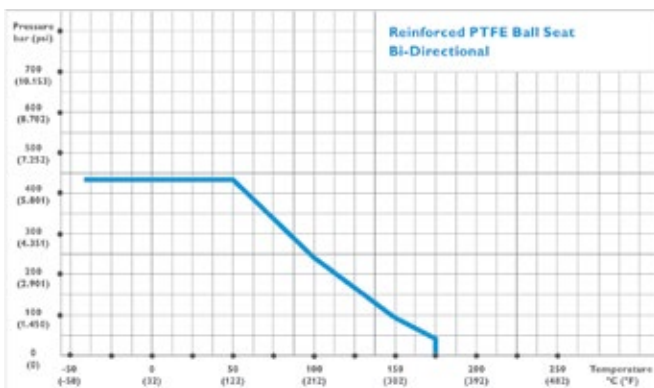

Note: Above-mentioned Pressure-Temperature Ratings are based on the standard material 316 stainless steel.
Other materials as shown on page 5 might have different Pressure-Temperature Ratings.

Low Temperature Limits:

KA1 / KA2 Type 420 bar (6.092 psi): -40°C

Low Temperature Limits:

KA3 Type 420 bar (6.092 psi): -30°C
 KA3 Type 689 bar (10.000 psi): -30°C
 KA4 Type 420 bar (6.092 psi): -30°C

KA Series I Dimensions

Ball Valve Dimensions

Female x Female

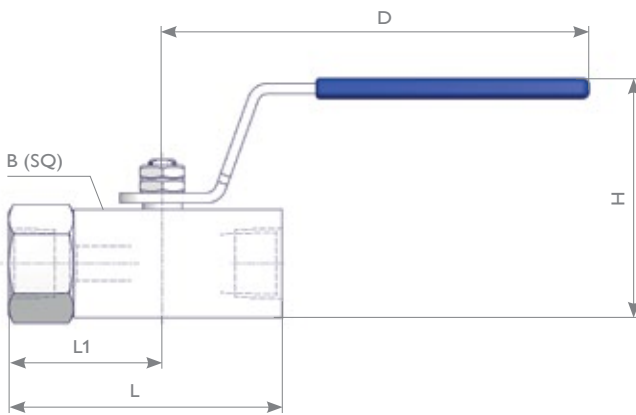

Twin Ferrule Compression Fitting

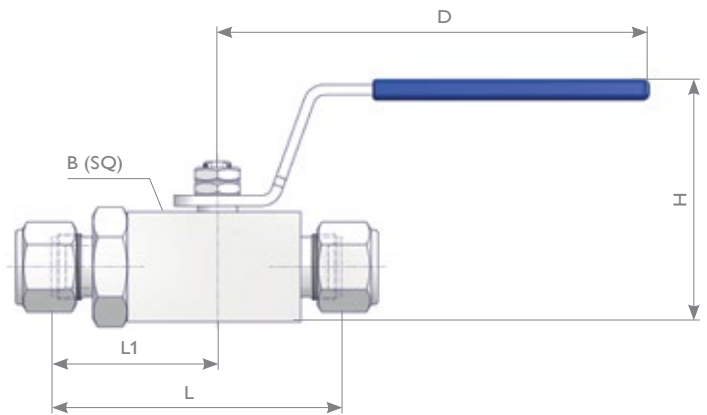

Male x Female

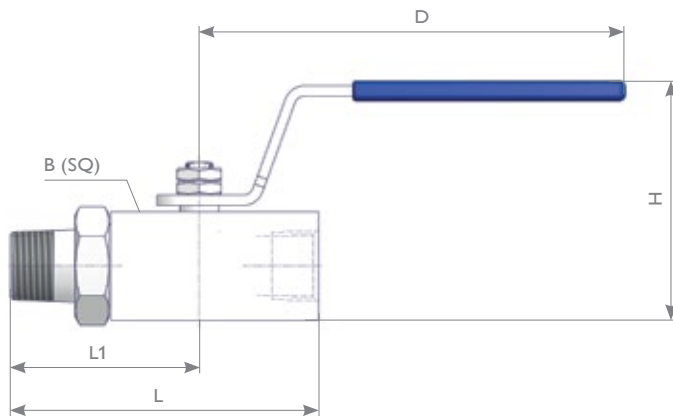

Ball Valve Dimensions

Style	Size	Max. allowable (Working) Pressure bar (psi)	Seat Material	Standard Part Number	Bore Size mm (inch)	Dimensions mm (inch)				
						L	B	D	H	L1
Female x Female	1/2 NPT	420 (6,092)	RPTFE	KA1-LN4LN4-S	10 (0.39")	80 (3.15")	31.5 (1.25")	130 (5.1")	70 (2.76")	45 (1.77")
		689 (10,000)	PEEK	KA3-LN4LN4-SH			38.0 (1.50")		76 (3.00")	
Male x Female		420 (6,092)	RPTFE	KA1-JN4LN4-S		90 (3.54")	31.5 (1.25")		70 (2.76")	55 (2.17")
		689 (10,000)	PEEK	KA3-JN4LN4-SH			38.0 (1.50")		76 (3.00")	
Twin Ferrule Compression Fitting (Tube O.D.)	10 mm	420 (6,092)	RPTFE	KA1-HK3HK3-S	84 (3.31")	31.5 (1.25")	70 (2.76")	48 (1.89")		
	12 mm			KA1-HK4HK4-S						
	3/8"			KA1-HK8HK8-S						
	1/2"			KA1-HK9HK9-S						

KB & KC Series I Standard Ball Valve Design

Standard Ball Valve Design – Bore Size 14 mm (0.55") and 20 mm (0.79")

Screwed Design – Stem Seal: Packing

Features

- Floating Ball Design – Bi-Directional
- Ball Valve Seat:
 - PEEK or
 - Reinforced PTFE optional (with higher operating torque)
- Self Venting Ball Seats
- Stem Seal: Reinforced PTFE Packing
- Metal Sealing between body and end connector
- Anti-Static Design as standard acc. to ISO 17292
- Max. allowable (Working) Pressure (PS):
 - 420 bar (6,092 psi) with PEEK Seats and
 - 150 bar (2,175 psi) with RPTFE Seats
- Anti-Blowout Stem Design
- Seat Leakage Class VI acc. to ANSI/FCI 70-2
- Positive Stop Pins
- All Non-wetted Parts in 316 Stainless Steel
- Fire Safe tested and certified – For PEEK Ball Valve Seat only
- Ball Valve tested and certified acc. to ISO 15848-1 (Measurement, test and qualification procedures for fugitive emissions)

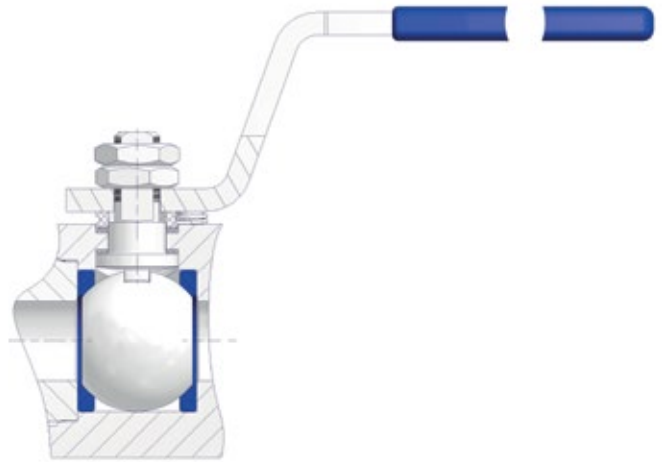

Standard Design Material 316



Design concerning Exotic Materials



Pressure-Temperature Ratings

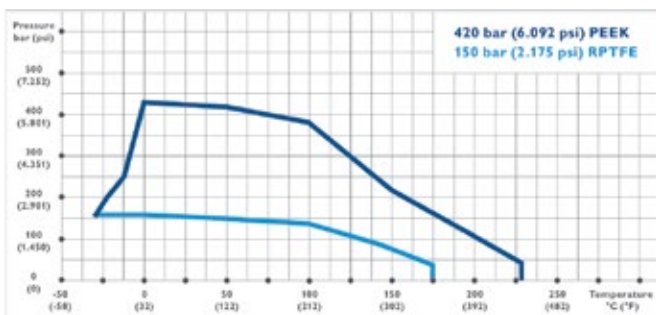

Above-mentioned Pressure-Temperature Rating is based on the standard material 316 stainless steel.

Other materials as shown on page 5 might have different Pressure-Temperature Ratings.

KB & KC Series I Dimensions

Ball Valve Dimensions

Female x Female

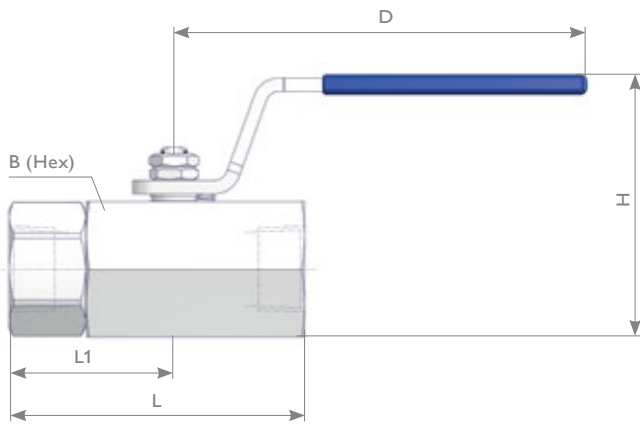

Male x Female

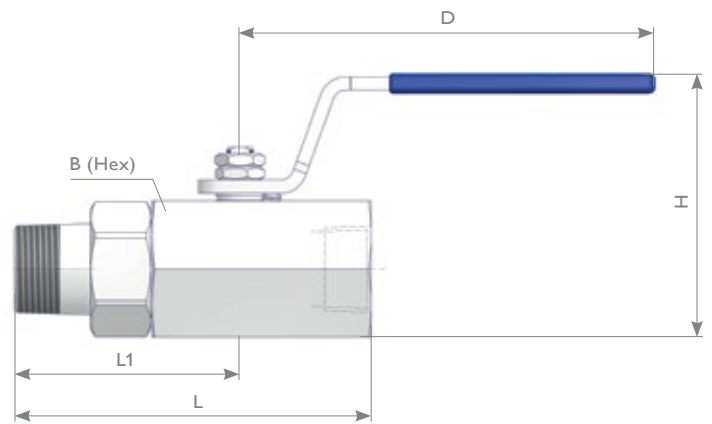

Ball Valve Dimensions

Style	Size	Max. allowable (Working) Pressure bar (psi)	Seat Material	Standard Part Number	Bore Size mm (inch)	Dimensions mm (inch)					
						L	B	D	H	L1	
Female x Female	1/2 NPT	150 (2,175)	RPTFE	KB1-LN4LN4-S	14 (0.55")	89.4 (3.52")	41.0 (1.61")	125.0 (4.92")	79.3 (3.12")	49.9 (1.96")	
		420 (6,092)	PEEK	KB3-LN4LN4-S							
Male x Female	3/4 NPT	150 (2,175)	RPTFE	KB1-LN6LN6-S		107.4 (4.23")	67.9 (2.67")				
		420 (6,092)	PEEK	KB3-JN6LN6-S							
Female x Female	1 NPT	150 (2,175)	RPTFE	KC1-LN6LN6-S		20 (0.79")	111.4 (4.39")	57.2 (2.25")	150.3 (5.92")	115.5 (4.55")	63.4 (2.50")
		420 (6,092)	PEEK	KC3-LN6LN6-S							
Male x Female	1 NPT	150 (2,175)	RPTFE	KC1-LN8LN8-S	132.4 (5.21")		84.4 (3.32")				
		420 (6,092)	PEEK	KC3-JN8LN8-S							

KA, KB & KC Series I Options

Ball Valve Options

Loose Handle

Handle is supplied separately.
(Option Code R)

KA	KB	KC
available	on request	



Lockable Handle

Valves can be locked in either the open or closed position with a padlock (Option Code W). Lockable Handle incl. Padlock (Option Code U).

KA	KB	KC
available		

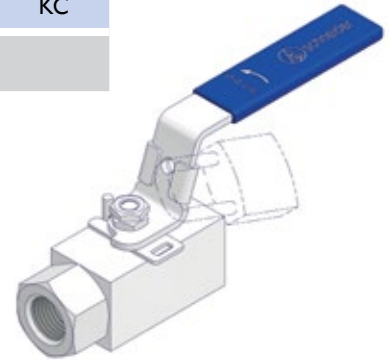

Oval Handle

Oval Handle – Optional to standard lever type.
(Option Code Q)

KA	KB	KC
available	–	



Multi-Ported Ball Valve

Three ports of same size. (Option Code T)

KA	KB	KC
available	on request	



Extended Body

Extended Body – Extended by approx. 60 mm (2.4") and a L1 of 115 (4.52") at KA, 128 (5.04") at KB and 145 (5.7") at KC Series. (Option Code E)

KA	KB	KC
available	on request	

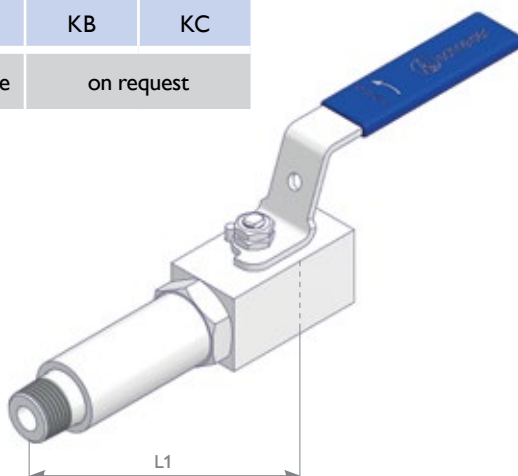

Panel Mount

Valve can be mounted to panels up to a thickness of 6 mm (0.24") – Delivered with suitable bolts. (Option Code C)

KA	KB	KC
on request		

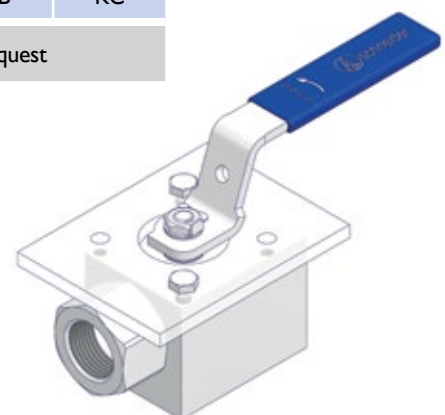

KA, KB & KC Series I Ordering Information

Ordering Information

				1	2	3	4	5	6	7	8	9	10	11	12	13	14	15	16	
				K	A	1	-	L	N	4	L	N	4	-	S	E	M			
KA	Ball Valve – Bore Size 10 mm																			
KB	Ball Valve – Bore Size 14 mm																			
KC	Ball Valve – Bore Size 20 mm																			
Seal Material																				
	Available for	Packing		Ball Seat																
1	KA	KB	KC	PTFE	Reinforced PTFE															
2	KA			Graphite	Reinforced PTFE															
3	KA	KB	KC	PTFE	PEEK															
4	KA			Graphite	PEEK															
Inlet				KA Series only																
Thread Type				Fitting Type																
LN	NPT Female			HK	Twin Ferrule Tube Fitting															
JN	NPT Male			TK	1/2 NPT Twin Ferrule Tube Fitting Male Connector															
JG	BSP Parallel (G) Male – EN837-1 (G 1/2 only)																			
Thread Size				Fitting Size																
2	1/4 – NPT only			3	10 mm															
4	1/2			4	12 mm															
6	3/4			8	3/8"															
8	1			9	1/2"															
Outlet																				
Thread Type				Fitting Type																
LN	NPT Female			HK	Twin Ferrule Tube Fitting															
JN	NPT Male			TK	1/2 NPT Twin Ferrule Tube Fitting Male Connector															
LM	Adjusting Nut BSP Parallel (G) Female – EN837-1 (G 1/2 only)																			
Thread Size				Fitting Size																
2	1/4 – NPT only			3	10 mm															
4	1/2			4	12 mm															
6	3/4			8	3/8"															
8	1			9	1/2"															
Material I Body																				
S	1.4401 / 1.4404 / 316 / 316L																			
F	Duplex UNS S31803																			
M	Alloy 400 UNS N04400																			
H	Alloy C-276 UNS N10276																			
Options – Specify in alphabetical order																				
B	Cleaned for Oxygen Service (on request)			E	Extended Body (other Series on request)															
C	Panel Mount (on request)			T	Multi Port Design (other Series on request)															
M	Wetted Parts with 3.1 Certificate			H	10,000 psi → Ball Seat in PEEK															
P	Pressure Test acc. to API 598																			
Operation Options																				
W	Lockable Handle			Q	Oval Handle															
U	Lockable Handle incl. Padlock			R	Loose Handle (other Series on request)															

Wetted Parts according to above mentioned material list are supplied according to NACE MR0175/MR0103 and ISO 15156 (latest issue).
 Note: Not every configuration which can be created in the ordering information is feasible / available.

BA Series I Double Block & Bleed Ball Valve Manifolds

Double Block & Bleed Valves

The Double Block & Bleed Ball Valve Manifolds are combining a Primary and Secondary Isolate Ball Valve and a choice of Ball or Needle Vent/Bleed Valve into one body for applications up to 10,000 psi (689 bar). The standard end connections are 1/2 NPT, for further options please see ordering information on page 19 or contact the factory.

Ball Valve Manifolds with Ball Pattern Isolate (Block) and Needle Pattern Vent

Side Vent - Type BADA

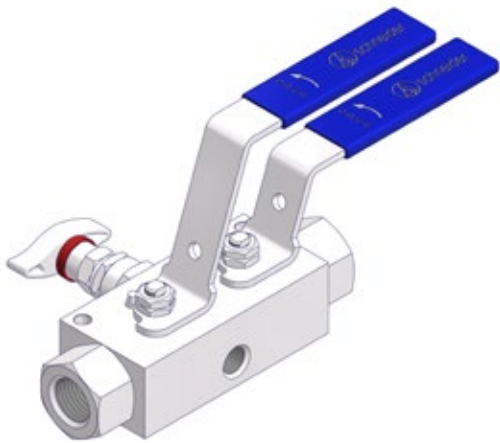

Bottom Vent - Type BADD/BADC

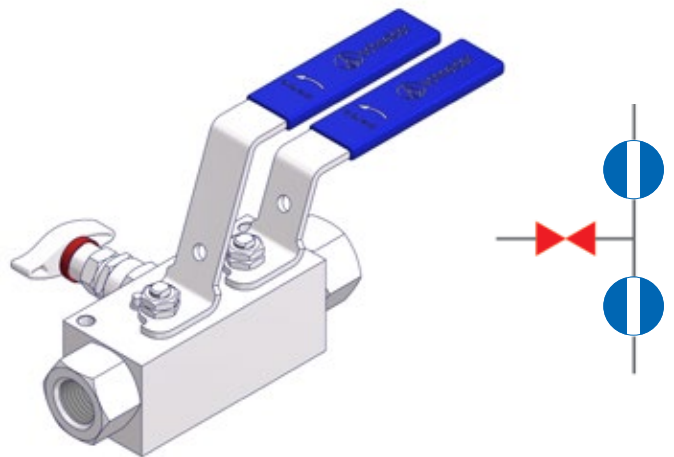

Ball Valve Manifolds with Ball Pattern Isolate (Block) and Vent

Type BAEA/BAEB

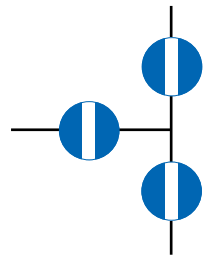
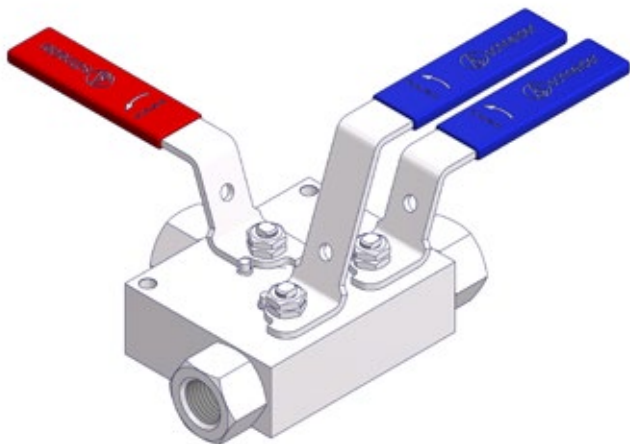

BA Series I Block & Bleed Ball Valve Manifolds

Block & Bleed Valves

The Double Block & Bleed Ball Valve Manifolds are combining a Primary Isolate Ball Valve and a choice of Ball or Needle Vent/Bleed Valve into one body for applications up to 10,000 psi (689 bar).

The standard end connections are 1/2 NPT, for further options please see ordering information on page 19 or contact the factory.

Ball Valve Manifolds with Ball Pattern Isolate (Block) and Needle Pattern Vent

Side Vent - Type BABA

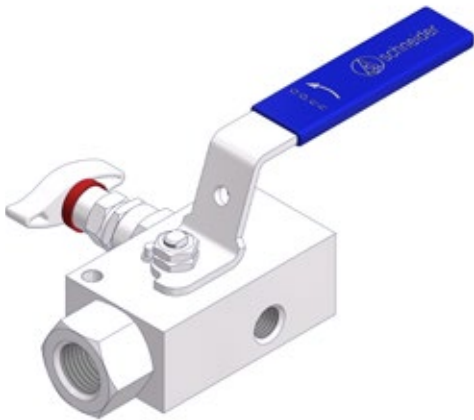

Bottom Vent - Type BABD/BABC

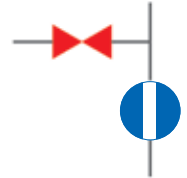
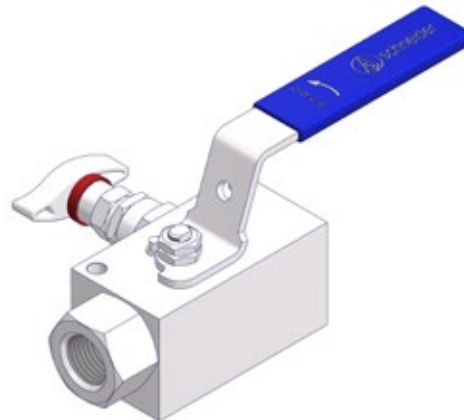

Ball Valve Manifolds with Ball Pattern Isolate (Block) and Vent

Type BACA/BACB

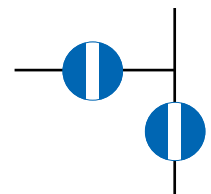
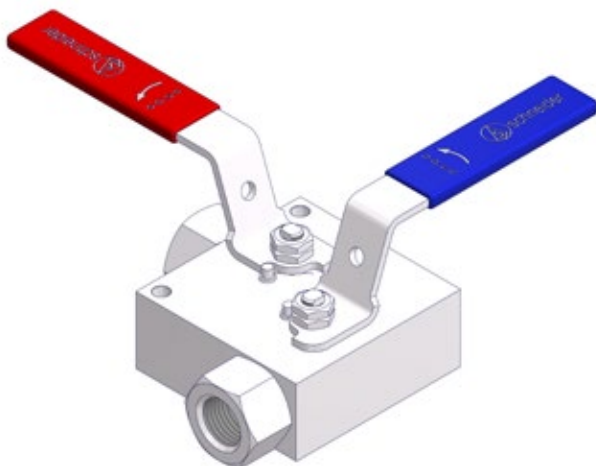

BA Series I Ball Valve Design

Standard Ball Valve Design – Bore Size 10 mm (0.39")

Features

- Floating Ball Design
- Ball Valve Seat:
 - Reinforced PTFE or
 - PEEK
- Ball Seats are encapsulated in end connector / body
- Stem Seal: Standard Packing in PTFE and Graphite
- Anti-Static Design as Standard acc. to ISO 17292
- Anti-Blowout Stem Design
- Seat Leakage Class VI acc. to ANSI/FCI 70-2
- Max. allowable (Working) Pressure (PS): 420 bar (6,092 psi) with PTFE and PEEK Seats → Bi-Directional
- Max. allowable (Working) Pressure (PS): 689 bar (10,000 psi) with PEEK Seats only → Uni-Directional
- Positive Stop Pins
- All Non-wetted Parts in 316 Stainless Steel

Note: Ball Valve Manifolds with Bore Size 14 / 20 mm available on request.

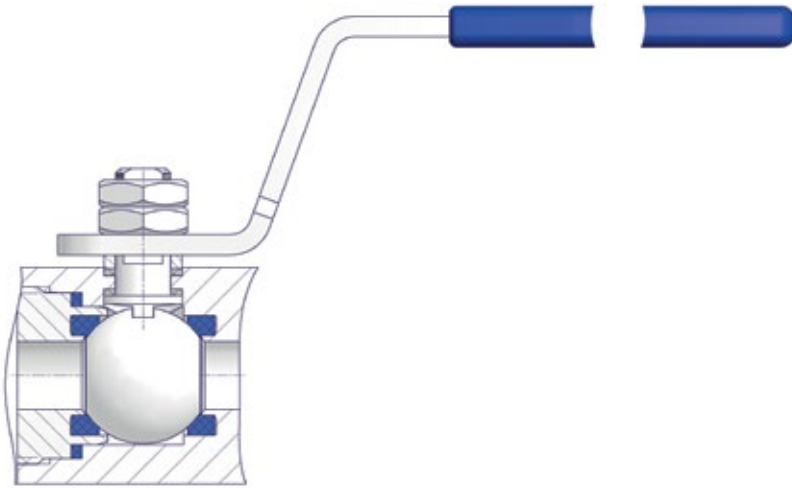

Lockable Handle Design

Valves can be locked in either the open or closed position with a padlock (Option Code W). Lockable Handle incl. Padlock (Option Code U).



Pressure-Temperature Ratings – Ball Valve

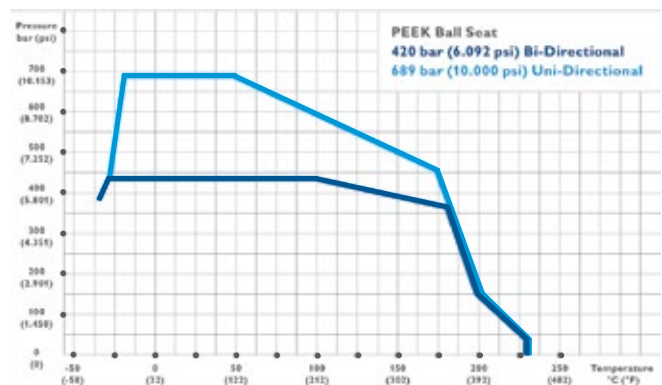
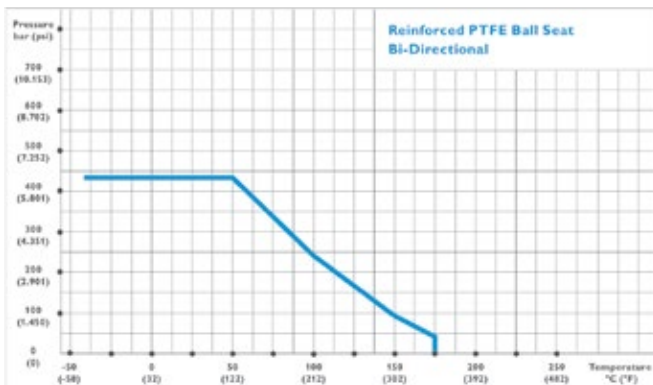

Note: Above-mentioned Pressure-Temperature Ratings are based on the standard material 316 stainless steel. Other materials as shown on page 18 might have different Pressure-Temperature Ratings.

Low Temperature Limits:

Seal Material: Ball Seat RPTFE -40°C
Ball Seat PEEK -30°C

BA Series I Needle Valve Design

Standard Needle Valve Design – Bore Size 5 mm (0.197")

Features

- Integral Valve Seat – Metal to Metal Seated
- Non-rotating Needle
- External Stem Thread – Packing below stem threads. Stem Threads are protected from process media (non-wetted, helps to prevent stems from galling)
- Stem with cold rolled threads
- Blow-out proof Needle
- Back Seat – Metal to Metal secondary needle seal
- Lock Pin – Eliminates unauthorized removal of the bonnet
- Color Coded Dust Cap for Operating thread protection
- Standard Packing in PTFE and Graphite available
- Max. allowable (Working) Pressure (PS):
420 bar (6,092 psi)
– 689 bar (10,000 psi) optional
- Anti-Tamper Valve Head Options available
- All non-wetted Parts in 316 stainless steel

Standard Design 420 bar (6,092 psi)

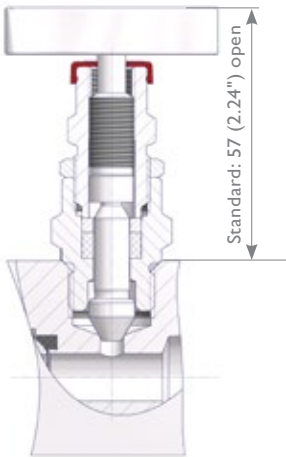

High Pressure Design 689 bar (10,000 psi)

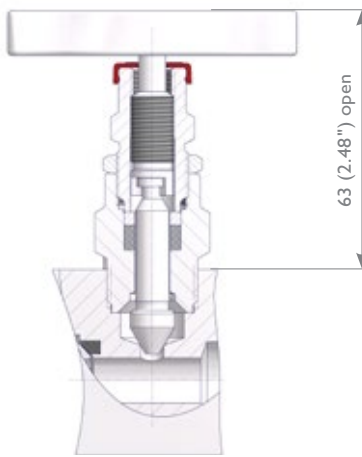

Body-to-Bonnet Seal is below the threads eliminating process fluid corrosion.

Anti-Tamper Valve Head Unit

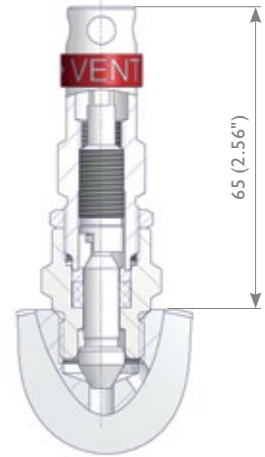

Pressure-Temperature Ratings – Needle Valve

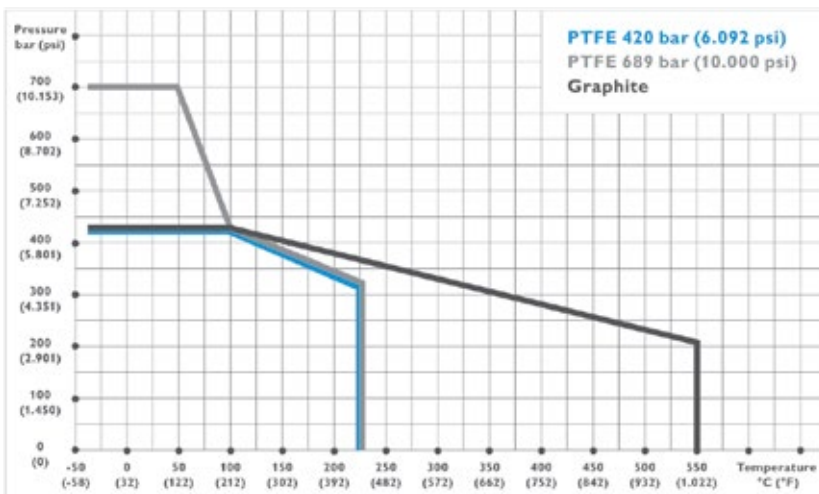

Low-temperature Limits:

- PTFE and Graphite Packing: -40°C (-40°F)
- Carbon Steel ASTM A105: -29°C (20.2°F)

BA Series I Double Block & Bleed Ball Valve Manifold Dimensions

Ball Valve Manifolds with Ball Pattern Isolate (Block) and Needle Pattern Vent

Side Vent - Type BADA

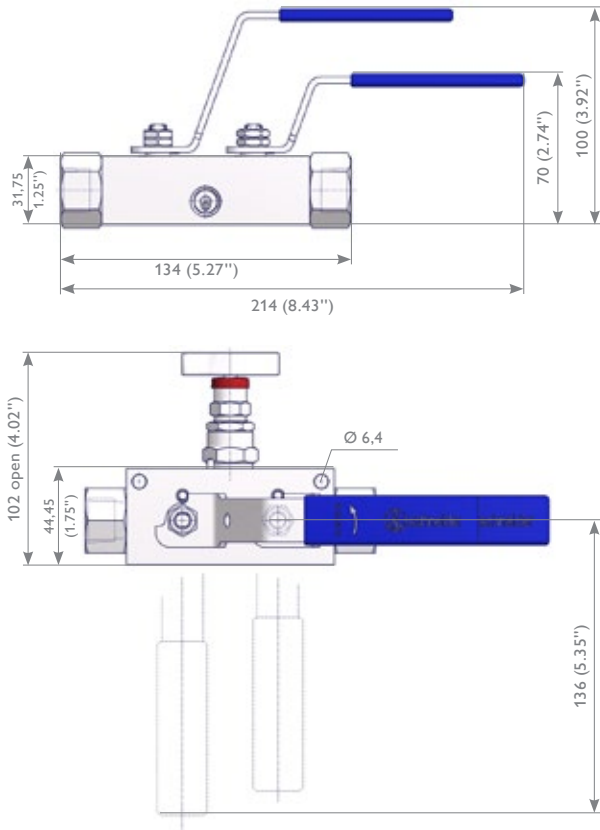

Bottom Vent - Type BADD/BADC

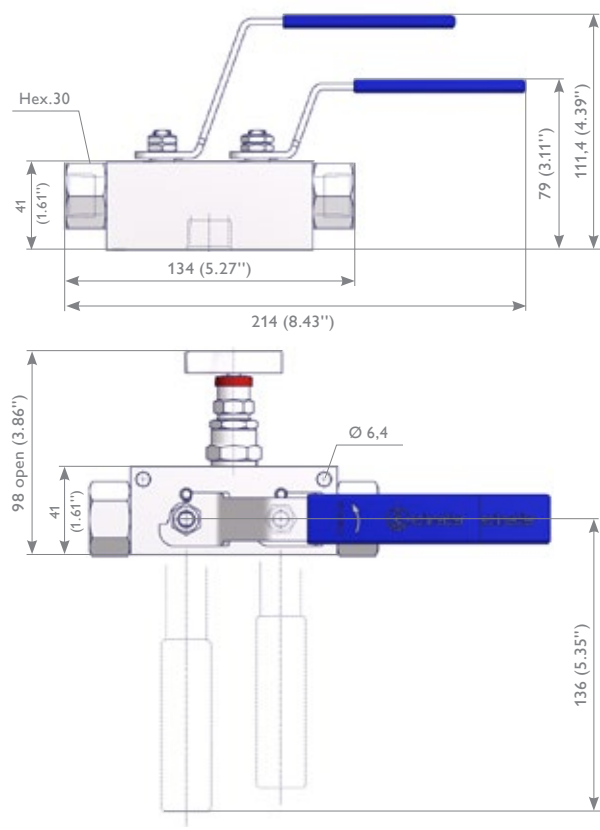

Ball Valve Manifolds with Ball Pattern Isolate (Block) and Vent

Side Vent - Type BAEA/BAEB

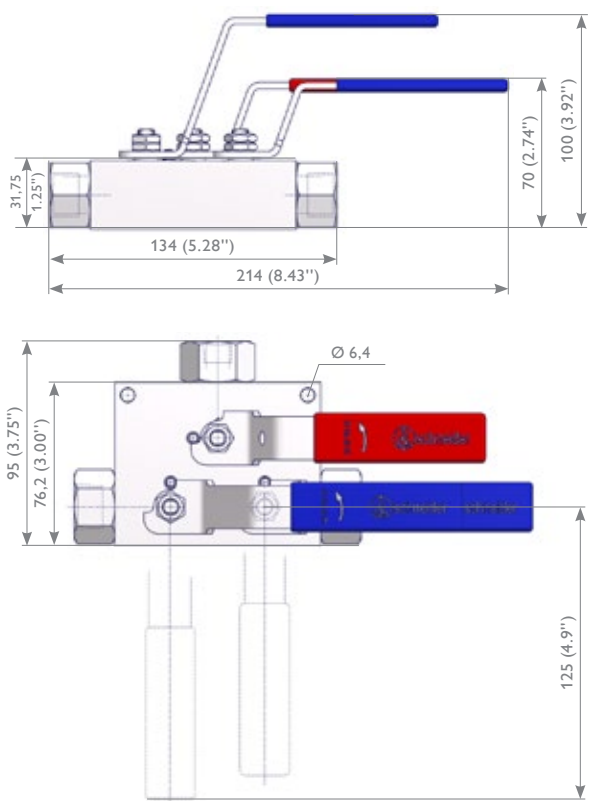

Note:
Ball Valve Manifold Dimensions
based on standard design 420 bar
(6.092 psi)

BA Series I Block & Bleed Ball Valve Manifolds Dimensions

Ball Valve Manifolds with Ball Pattern Isolate (Block) and Needle Pattern Vent

Side Vent - Type BABA

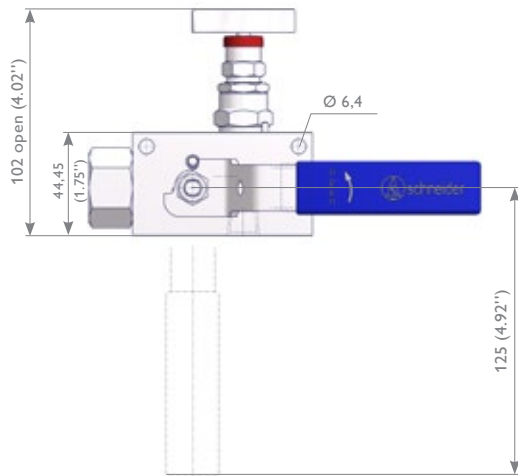
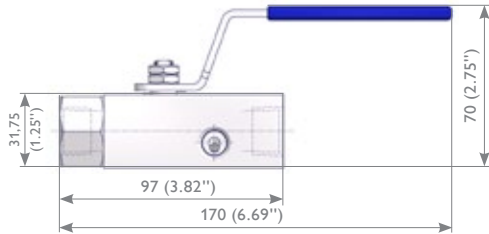

Bottom Vent - Type BABD/BACC

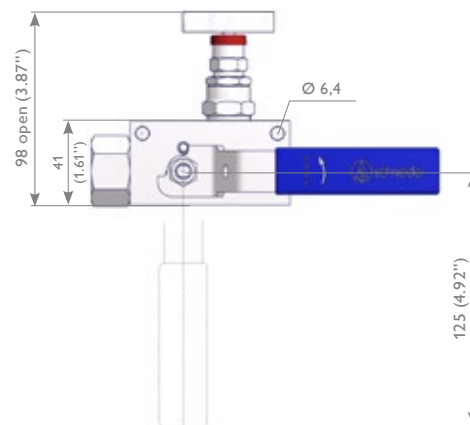
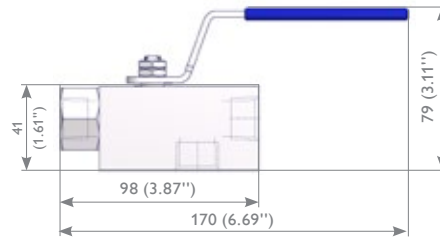

Ball Valve Manifolds with Ball Pattern Isolate (Block) and Vent

Type BACA/BACB

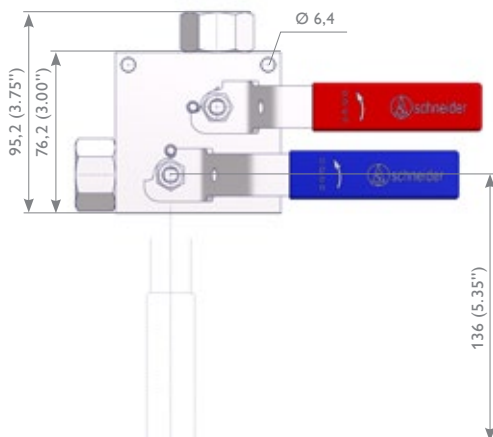
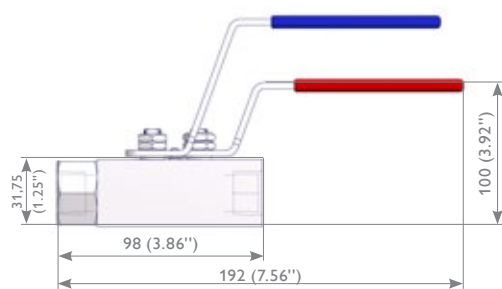

Note:
Ball Valve Manifold Dimensions
based on standard design 420 bar
(6.092 psi)

BA Series I Materials and General Features

Materials

	Type	Components	Stainless Steel	Exotic Materials					
Wetted Parts	Ball Valve	Body	316/316L	Alloy 400	Alloy C-276	Duplex			
		Body End Connector							
		Ball							
		Stem							
		Ball Seat					Reinforced PTFE or PEEK		
		Body Seals					PTFE, Reinforced PTFE or Graphite		
	Needle Valve	Bonnet	316/316L	Alloy 400	Alloy C-276	Duplex			
		Needle							
		Packing					PTFE or Graphite		

All Non-wetted Parts in 316 Stainless Steel except Handle Grip in Vinyl

General Features

Sour Gas Service:

Wetted parts according to a.m. material list are supplied as standard according to NACE MR0175/MR0103 and ISO 15156 (latest issue).

Pressure Test:

A shell test at 1.5 times the max. allowable (working) pressure and a seat leakage test are performed acc. to EN 12266-1 - P10, P11 and P12 respectively MSS-SP61 (and complies also with ASME B31.1 and B31.3) at every standard AS-Schneider Ball Valve Manifold → 100% Pressure Tested!

Pressure Test acc. to API 598 on request.

Certification:

Certified Mill Test Report (CMTR) as Inspection certificate 3.1 acc. to EN 10 204 for valve body material and pressure test available on request.

PMI Test on request.

Manufactured acc. to the following Codes and Specifications

- ASME B16.34 Valves – Flanged, Threaded and Welding End
- ASME B31.3 Process Piping
- ASME B31.1 Power Piping

BA Series Ball Valve Manifolds | Ordering Information

Ordering Information

	1	2	3	4	5	6	7	8	9	10	11	12	13	14	15	16	17	18
	B	A	D	A	S	1	-	L	N	4	L	N	4	-	A			
BA	Ball Valve Manifold – Bore Size 10 mm																	
Type																		
D	Double Block & Bleed Ball x Ball x Needle																	
E	Double Block & Bleed Ball x Ball x Ball																	
B	Block & Bleed Ball x Needle																	
C	Block & Bleed Ball x Ball																	
Vent Connection																		
Size																		
A	1/4 NPT Female																	
B	1/2 NPT Female																	
C	1/4 NPT Female																	
D	1/2 NPT Female																	
Orientation																		
	Side Vent																	
	Side Vent (Not for BAD/BAB Type)																	
	Bottom Vent (not for BAE/BAC Type)																	
	Bottom Vent (not for BAE/BAC Type)																	
Material																		
S	316/316L																	
F	S31803 (Duplex)																	
M	Alloy 400																	
H	Alloy C-276																	
Seal Material																		
Packing																		
1	PTFE																	
2	Graphite																	
3	PTFE																	
4	Graphite																	
Ball Seat																		
	Reinforced PTFE																	
	Reinforced PTFE																	
	PEEK																	
	PEEK																	
Inlet																		
LN	NPT Female Thread																	
JN	NPT Male Thread																	
TK	1/2 NPT Female Thread c/w Twin Ferrule Tube Fitting Connector																	
Thread Size																		
2	1/4"																	
3	3/8"																	
4	1/2"																	
6	3/4"																	
Fitting Size (for TK-Type)																		
3	10 mm																	
4	12 mm																	
8	3/8"																	
9	1/2"																	
Outlet																		
LN	NPT Female Thread																	
JN	NPT Male Thread																	
TK	1/2 NPT Female Thread c/w Twin Ferrule Tube Fitting Connector																	
Thread Size																		
2	1/4"																	
3	3/8"																	
4	1/2"																	
6	3/4"																	
Fitting Size (for TK-Type)																		
3	10 mm																	
4	12 mm																	
8	3/8"																	
9	1/2"																	
Options – Specify in alphabetical order																		
A	Vent Port Plugged																	
M	Wetted Parts with 3.1 Certificate																	
P	Pressure Testing acc. to API598																	
H	10,000 psi → Ball seat in PEEK																	
Operation Options*																		
W	Lockable Handle																	
U	Lockable Handle Incl. Padlock																	

* Option Code W and U: Needle Valve with Anti-Tamper Head Unit

K Series I General Features

K Series Ball Valves

AS-Schneider's K Series Ball Valves are very robust, forged ball valves which are designed especially for severe service for the chemical and petrochemical process industry. They Are especially used for close coupled hook-ups. End connector and valve body are full penetration welded for environmental protection.

Features

- Floating Ball Design – Bi-Directional
- 2 Piece Design – Fully Welded
- Forged Body in 1.0460 / A105 and 316
- Ball Bore Size 10 mm (0.39")
- Ball Seats are encapsulated in Seat Carrier – Material: PTFE or Carbon filled PTFE
- Stem Seal: PTFE or Graphite
- Max. allowable (Working) Pressure (PS): 250 bar (3,626 psi) | Class 1,500
- Anti-Blowout Stem Design
- Low Operation Torque
- Fire Safe tested acc. to ISO 10497 / API 607 – With Graphite Seals only
- Wide Range of Connections available
- Pressure Test acc. to EN 12266 and MSS SP61 – Leakage Rate A acc. to EN 12266-1
- Seat Leakage Class VI acc. to ANSI/FCI 70-2
- Materials comply to NACE MR 0175 / MR0103 / ISO 15156
- Ergonomic Oval Handles – Can be locked in opened and closed Position

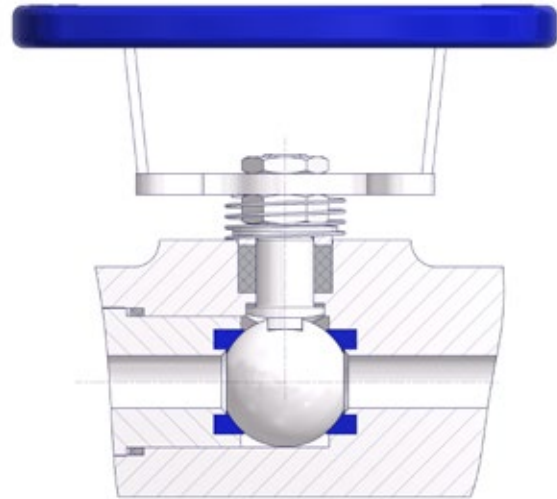

Optional Features

- Fugitive Emission Bonnet – TA-Luft conformitiy optional
- Anti-Static Design
- Vented Ball
- Spring Loaded Ball Seat } Uni-Directional
- Ball Seat: PEEK, PCTFE and PFA
- Stellited Ball
- Padlock for Lockable Handle
- Extended Stem
- Cryogenic Applications
- Special Cleaning for Chlorine and Oxygen Service
- Optional Materials: ASTM A350-LF2, Alloy 400, Alloy C-276, Duplex, Etc.

For further Details, please contact the factory.

Components	Carbon Steel	Stainless Steel
	Material / Material No.	
Body	1.0460 / A105	F316 / F316L
Body End Connector		
Ball	316 / 316L	
Stem		
Seat Carrier	316 /316L	
Disc Spring	Inconel 718	
Primary Stem Seal	Reinforced PTFE	
Ball Seat	PTFE or Reinforced PTFE	
Packing	PTFE or Graphite	
Body Seals		
Gland	316	
Hex Nut	300 Series	
Locking Plate		
Oval Handle		
Handle Grip	Vinyl	
Stop Screw	A2	

Wetted components listed in **bold**.

K Series I Standard Ball Valve Design

Standard Ball Valve Design

Single-Ported Ball Valve with following connections:

Inlet: Flanged, Threaded or Welded

Outlet: Threaded or Flanged

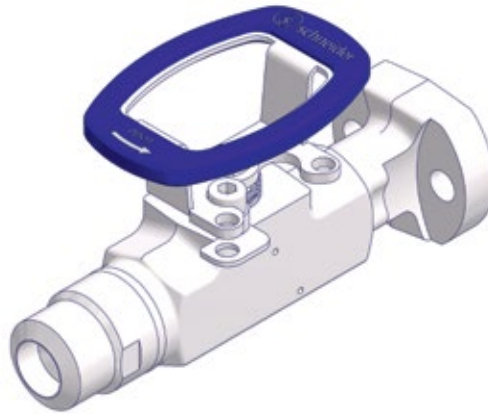

Multi-Ported Ball Valve with following connections:

Inlet: Flanged, Threaded or Welded

Outlet – Multiport Type: Threaded or Flanged & Threaded

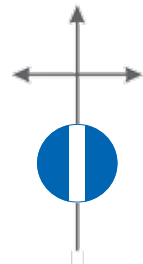

Pressure-Temperature Ratings

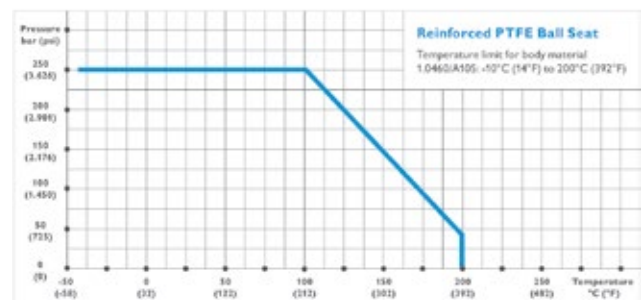
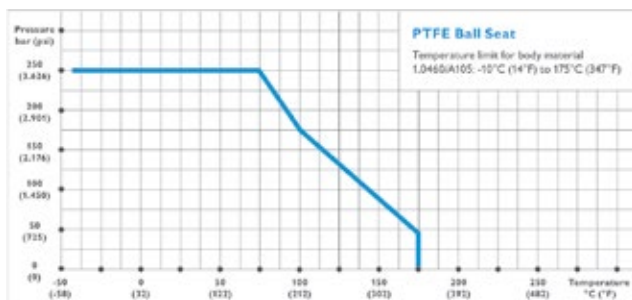

K Series I Operation and Bonnet Options

Short Handle

Similar in shape to the Standard oval handle but shortened by 18mm

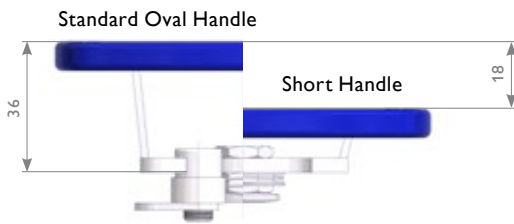

Extended Handle



Fugitive Emission Bonnet (FE Bonnet)

with lantern ring and threaded vent port



Extended Bonnet for Cryogenic Service



K Series I Ordering Information

	1	2	3	4	5	6	7	8	9	10	11	12	13	14	15	16	17	18	19	20	
	K	D	A	S	-	B	F	S	S	A	A	-	6	P	N	6	-				
K Ball Valve Fully Welded – Bore Size 10 mm																					
Rating																					
D	Class 900																				
E	Class 1,500																				
Bonnet																					
A	Standard			L	Extended Bonnet for Cryogenic Service																
F	Fugitive Emission Bonnet																				
Ball / Ball Seat Design																					
S	Standard (Bi-Directional)																				
V	Vented Ball (Uni-Directional)																				
Inlet																					
A	Flanged			F	Female Thread																
B	Butt Weld End			M	Male Thread																
S	Socket Weld End																				
Outlet																					
A	Flanged			F	Female Thread																
B	Butt Weld End			M	Male Thread																
S	Socket Weld End																				
Material Body																					
C	A105 / 1.0460			M	Alloy 400 UNS N04400																
S	1.4404 / 1.4401 / 316 / 316L			A	Alloy 20 UNS N08020																
H	Alloy C-276 UNS N10276																				
Material Ball																					
S	1.4404 / 1.4401 / 316 / 316L			M	Alloy 400 UNS N04400																
H	Alloy C-276 UNS N10276			A	Alloy 20 UNS N08020																
Material Packing																					
A	PTFE			W	Carbon filled PTFE (TA-Luft)																
B	Graphite																				
Material Ball Seat																					
A	PTFE			K	PCTFE																
C	Carbon filled PTFE			P	PEEK																
F	PFA																				
Inlet																					
Thread Type																					
N	NPT			4	1/2" pipe			T	Flange Interface												
				6	3/4" pipe																
				8	1" pipe																
				Socket Weld End																	
				4	For 1/2" pipe																
				6	For 3/4" pipe																
Thread Size																					
2	1/4			N	Schedule 40			D	IEC 61518-A												
3	3/8			P	Schedule 80																
4	1/2			Q	Schedule 160																
6	3/4																				
8	1			A	Socket Weld																
Outlet																					
Thread Type																					
N	NPT			4	1/2" pipe			T	Flange Interface												
				6	3/4" pipe																
				8	1" pipe																
				Socket Weld End																	
				4	For 1/2" pipe																
				6	For 3/4" pipe																
Thread Size																					
2	1/4			N	Schedule 40			D	IEC 61518-A												
3	3/8			P	Schedule 80																
4	1/2			Q	Schedule 160																
6	3/4																				
8	1			A	Socket Weld																
Options – Specify in alphabetical order																					
M	Wetted Parts with 3.1 certificate			B	Cleaned for Oxygen Service			A	Extended Handle												
T	Multiport Design - Three outlet ports of same size			D	Cleaned for Chlorine Service																
				P	Cleaned for Phosgene Service																
				K	Cleaned for Isocyanate Service																

Wetted Parts according to a.m. material list are supplied according to NACE MR0175/ MR0103 and ISO 15156/17945 (latest issue)
 Note: Not every configuration which can be created in the ordering information if feasible / available.

KM Series I Metal Seated Ball Valves

KM Series I Metal Seated Ball Valves

Extreme operating conditions with temperatures up to 450°C (842°F) and pressures up to 420 bar (6,092 psi) require special sealing technology in ball valves.

Standard Soft Seated Ball Valves simply aren't ready for this kind of requirements. Their plastic seals would fail. Metal Seated Ball Valves don't have this problem. However, most Metal Seated Ball Valves are not available for high pressures and also not available for smooth operation. AS-Schneider entered the Metal Seated Ball Valve arena with the KM Series.

When developing the KM Series AS-Schneider uses the latest surface and material knowledge combined with comprehensive engineering know-how. The result is a ball valve with zero leakage even under extreme operating conditions with respect to working pressure and temperature – even though a smooth operation is provided.

Features

- 2 Piece Design – Fully Welded
- Ball Bore Size 10 mm (0.39")
- Seat and Ball Surfaces coated with Hardalloy and Carbide compounds
- 'Dissolution' Ball Valve Design and an outstanding axial bearing washer at the stem – For smooth operation (even at high working pressures)
- Double Sealing System in fugitive emission bonnet consisting of premium-quality graphite sealing rings
- Pressure Rating: Class 2,500
- Max. allowable Temperature (TS): -29°C (-20°F) to 450°C (842°F)
- Anti-Blowout Stem Design
- Can be locked in opened and closed position
- Oval Handle can be dismantled during operation
- Even Non-wetted Parts are made of 316 Stainless Steel for operation in corrosive environments
- Seat Leakage: ANSI / FCI 70-2 Class V
- Body Material: 1.4401 / 316 or 1.0460 / A105
- Materials comply to NACE MR 0175 / MR0103 / ISO 15156
- Ball Valve meets requirements of TA-Luft (leak rate < 4,6 x 10⁻⁶ mbar x l/s)
- Fire Safe tested acc. to ISO 10497 and API 607
- Design Basis: ISO 17292, ASME B16.34, MESC SPE 77/170, MESC SPE 77/110

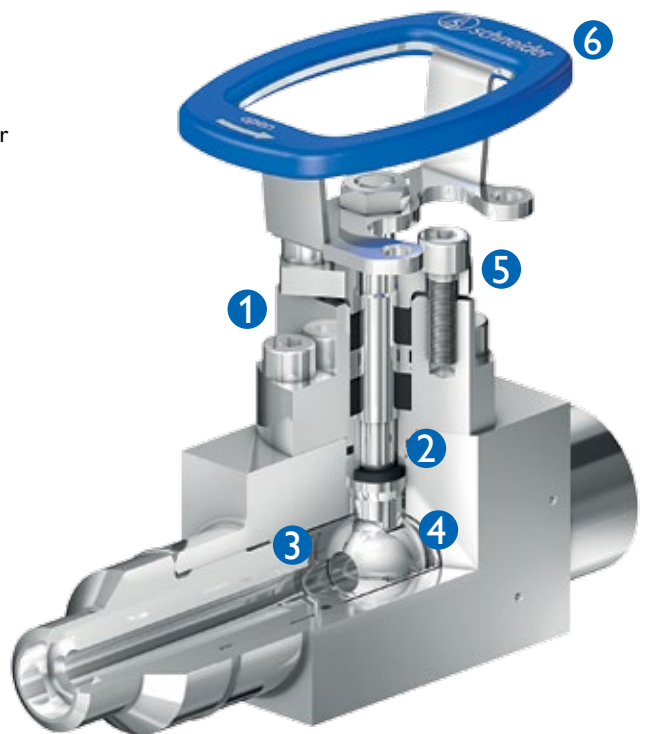

Pressure-Temperature Rating

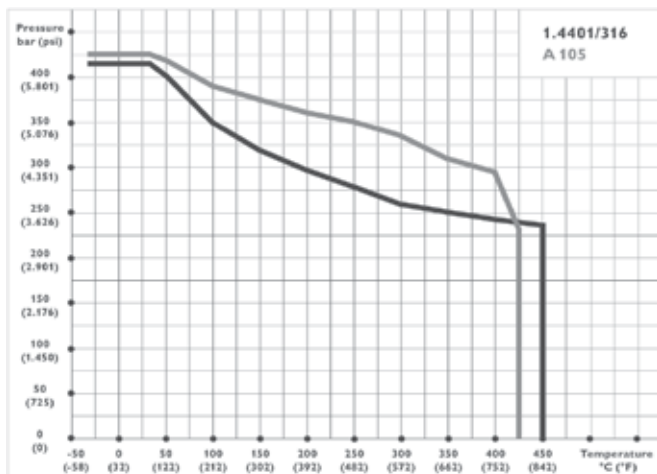

1. Fugitive Emission Bonnet with Double Sealing System and Lantern Ring
2. Outstanding Axial Bearing washer integrated at the Stem
3. Smooth Operation due to 'Dissolution' Ball Valve Design
4. Seat and Ball Surfaces coated with Hardalloy and Carbide compounds
5. Adjustment Capability for Packing with Gland Follower
6. Oval Handle can be dismantled during operation

KM Series I Innovative 'Disolution' Ball Valve Design

Best tightness performance with maximum comfort

Large forces are required to preserve the tightness between ball and ball seats and the tightness between ball seats and valve body. These forces are often applied by a screw connector or when assembling the ball valve body (for example a three piece body).

In a conventional design, the transmission of force of the ball seat to valve body sealing is being effected directly by the ball, so as the pressure increases, the actuation torque also rises significantly. The max. allowable (Working) Pressure (PS) of Metal Seated Ball Valves from most manufacturers is thus about 100 bar – because this is the limit that still permits actuation of the valve.

With the 'Disolution' Ball Valve Design, AS-Schneider has introduced an innovative solution. This patented design offers an optimum distribution of forces and loads in the valve, so they are only present where they are actually needed. The ball valve can thus be actuated without problems even under extreme conditions.



Conventional Ball Valve Design

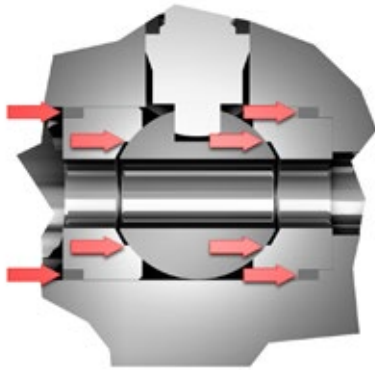

The forces required to maintain the tightness are stressing all components - even the ball and ball seats. The operating torque is thus very high.

'Disolution' Ball Valve Design

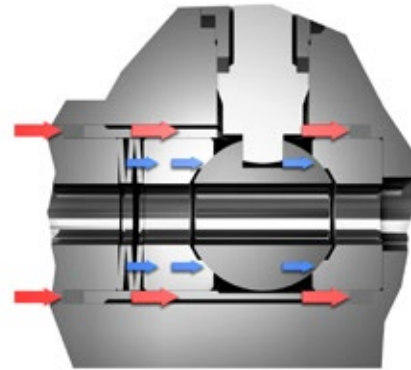

The forces needed to maintain the tightness between ball seat and valve body are only directed onto the corresponding graphite seal rings. The ball is only spring-loaded, which ensure a low, defined, minimum pressure off the balls on the ball seat. A smooth operation is the consequence.

KM Series I Ordering Information

				1	2	3	4	5	6	7	8	9	10	11	12	13	14	15	16
				K	M	9	-	J	N	4	L	N	4	-	S				
KM Metal Seated Ball Valve Series																			
Seal Material																			
Packing		Ball and Ball Seat		End Connector Seal Ring															
9	Graphite	Coated with : Nickelhardalloy with Tungston carbide		PTFE															
Inlet																			
Thread Type				Butt Weld End				Flange Interface											
LN	NPT Female Thread		A4	1/2" pipe		TD Acc.IEC 61518 - TypeA													
LH	BSP Parallel (G) Female Thread		A6	3/4" pipe															
JN	NPT Male Thread		A8	1" pipe															
				Socket Weld End															
				D4 For 1/2" pipe															
				D6 For 3/4" pipe															
Thread Size				Wall Thickness BW				1 Flange Interface											
4	1/2		N	Schedule 40															
6	3/4		P	Schedule 80															
				Socket Weld End															
Outlet																			
Thread Type				Butt Weld End				Flange Interface											
LN	NPT Female		A4	1/2" pipe		TD Acc.IEC 61518 - TypeA													
LH	BSP Parallel (G) Female - DIN3852		A6	3/4" pipe															
				A8 1" pipe															
				Socket Weld End															
				D4 For 1/2" pipe															
				D6 For 3/4" pipe															
Thread Size				Wall Thickness BW				1 Flange Interface											
4	1/2		N	Schedule 40															
6	3/4		P	Schedule 80															
				Socket Weld End															
Material Body Ball and Ball Seat																			
C	1.0460/A105 (Body) 1.4401/316 incl. coating (Ball and Ball Seat)																		
S	1.4401/316 (Body) 1.4401/316 incl. coating (Ball and Ball Seat)																		
Options – Specify in alphabetical order																			
B	Cleaned for Oxygen Service																		
E	Extended Body																		
G	Outlet port plugged																		
M	Wetted Parts with 3.1 certificate																		
P	Pressure Testing acc. to API 598																		
T	Multiport Design - Three outlet ports of same size																		
Operation Options																			
U	Padlock for Lockable Handle																		

Wetted Parts according to a.m. material list are supplied according to NACE MR0175/MR0103 and ISO 15156/17945 (latest issue)

Notes: Not every configuration which can be created in the ordering information is feasible / available.

Low Pressure Ball Valves 1,000 psi (69 bar)

Features

- Floating Ball Design
- One Piece Design
- Reduced Bore
- Ball Valve Seat – PTFE
- Body and Stem: 316 Stainless Steel
- Stem Seal: PTFE
- Max. allowable (Working) Pressure (PS): 69 bar (1,000 psi)
- Anti-Blowout Stem Design
- Connections: Female NPT Threaded
- Test Standard: API 598
- Steam Rating: 125 psi (8.6 bar) WSP
- NACE MR0175 Full Compliance
- 2 Handles are available:
 - Lockable Handle
 - Butterfly Handle

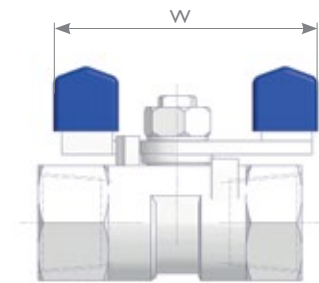
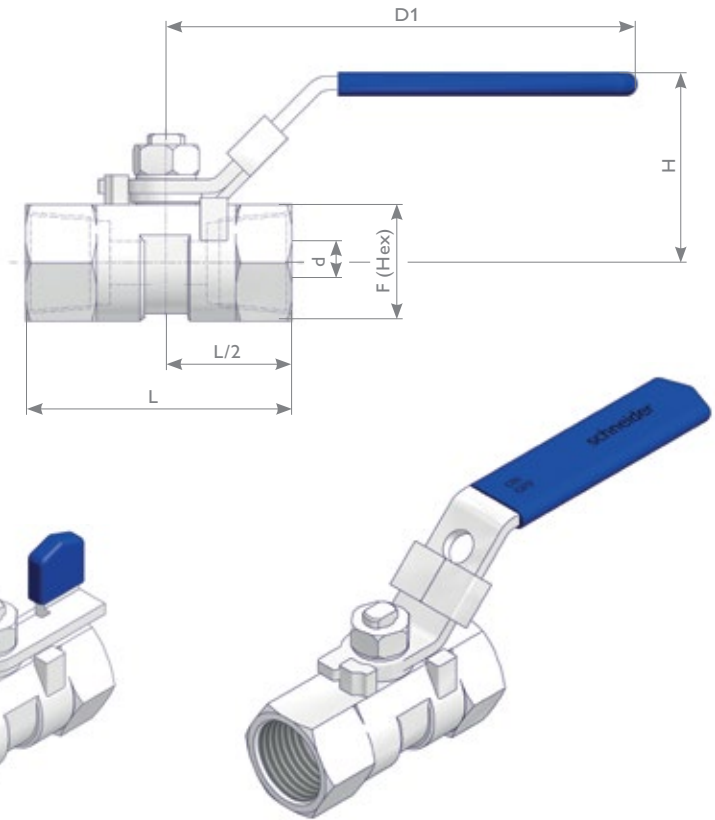

Pressure-Temperature Rating

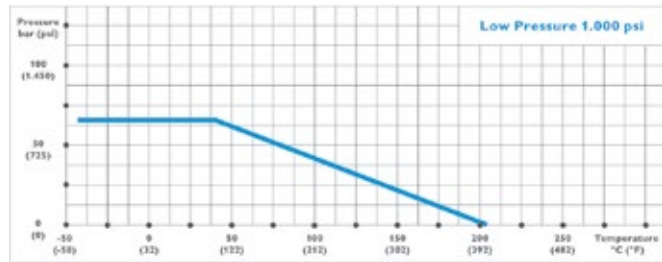

Materials of Construction

Components	Material	Components	Material
Body	ASTM A351 Gr. CF8M	Packing	PTFE
Cap	ASTM A351 Gr. CF8M	Washer	304
Ball	ASTM A351 Gr. CF8M	Spring Washer	304
		Hexagon Nut	304
Stem	316	Handle	304
Ball Seat	PTFE	Handle Grip	Vinyl
Thrust Washer	PTFE	Locking Plate	304

Ball Valve Dimensions

Size D	Handle Type	d		D1		W		F (Hex)		L		H		Part Number
		mm	inch	mm	inch	mm	inch	mm	inch	mm	inch	mm	inch	
1/4 NPT	Lockable Handle	5.0	0.20	66.0	2.60	51.0	2.00	17.0	0.67	39.0	1.54	31.0	1.22	520519
	Butterfly Handle											30.0	1.18	520731
3/8 NPT	Lockable Handle	7.0	0.28	76.0	3.00			21.0	0.83	44.0	1.73	35.0	1.38	521561
1/2 NPT	Lockable Handle	9.2	0.36	96.0	3.78	56.5	2.22	25.0	0.98	56.0	2.20	43.0	1.69	520594
	Butterfly Handle											34.0	1.34	520730
3/4 NPT	Lockable Handle	12.5	0.49	96.0	3.78			32.0	1.26	59.0	2.32	46.0	1.81	522008
1 NPT		16.0	0.63	110.0	4.33			38.0	1.50	71.0	2.80	50.0	1.97	522135

YOUR GLOBAL PARTNER

for Instrumentation and
Double Block & Bleed Valves



Visit us on:



ARMATURENFABRIK FRANZ SCHNEIDER GMBH + CO. KG
World Headquarters
Bahnhofplatz 12, 74226 Nordheim, Germany
Tel: +49 7133 101-0
www.as-schneider.com



ARMATURENFABRIK FRANZ SCHNEIDER SRL
Gradinari 32-38, 100404 Ploiesti
Romania
Tel: +40 244 384 963
www.as-schneider.ro



AS-SCHNEIDER ASIA-PACIFIC PTE. LTD.
970 Toa Payoh North, #02-12/14/15, Singapore 318992,
Singapore
Tel: +65 62 51 39 00
www.as-schneider.sg



AS-SCHNEIDER AMERICA, INC.
17449 Village Green Dr, Houston, TX 77040
United States of America
Tel: +1 281 760 1025
www.as-schneider.com



AS-SCHNEIDER MIDDLE EAST FZE
P.O. Box 18749, Dubai
United Arab Emirates
Tel: +971 4 880 85 75
www.as-schneider.ae



AS-1901-EN | April 2021